

MODEL 410

Auto-Charged Capacitor Trip Device

- Self-contained standby power source
- Maintains full operating voltage for a minimum of two days
- Discharge manually, or with an external control device

DESCRIPTION

The Model 410 Auto-Charged Capacitor Trip Device is a high speed capacitor-type circuit breaker tripping unit. It differs from the conventional capacitor trip device in that it has a self-contained standby power source, which is capable of maintaining full operating voltage for several days.

This device is primarily for use with circuit breakers which require some form of AC power for their closing operation; i.e., circuit breakers having either a stored energy closing mechanism with an AC-operated release coil, or an AC solenoid-operated closing mechanism. There are no field adjustments required.

The Model 410 has a cover-actuated safety switch, which discharges the capacitor and disconnects the primary source when the cover is removed.

The Model 410 can be tripped manually, or by means of a voltage-sensing or phase loss monitor. Versions are available for 120VAC or 240VAC operations.

TYPICAL APPLICATION

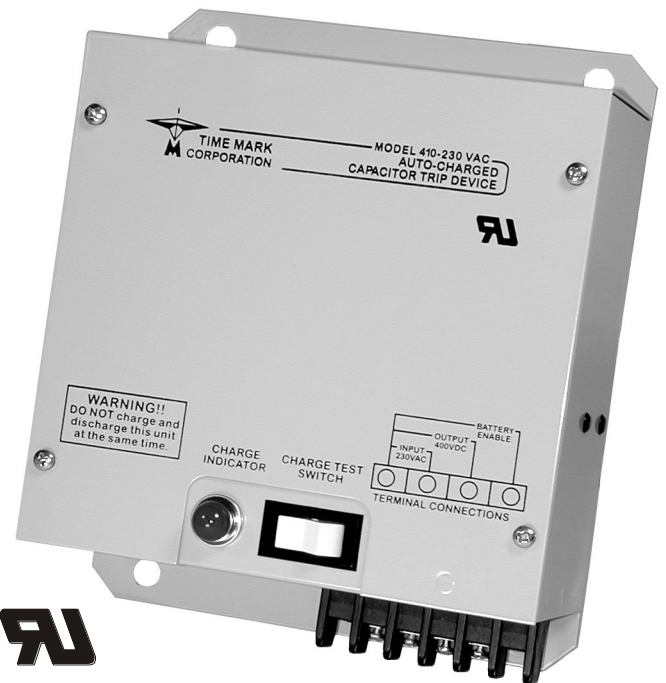
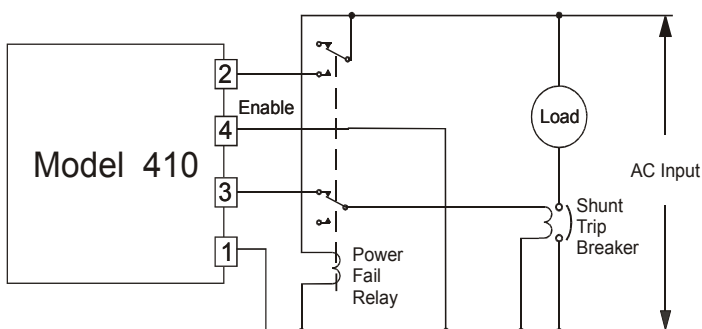

SPECIFICATIONS

Model	410-120	410-230
Nominal AC voltage (phase to phase)	120VAC	208/230VAC
Input voltage range	108-132VAC	216-264VAC
Frequency	60Hz	60Hz
Battery	4,000mAh, 1.2v, 'D' cell NiCad (user replaceable)	
Output voltage	380VDC minimum	
Output power	28.7 watt seconds	
Operating temperature	-20° to +131° F	
Humidity tolerance	0 - 97% w/o condensation	
Case material	20 gauge CRS	
Mounting	Surface	
Weight	3.2 lbs	
Agency approval	UL Recognized	

DIMENSIONS

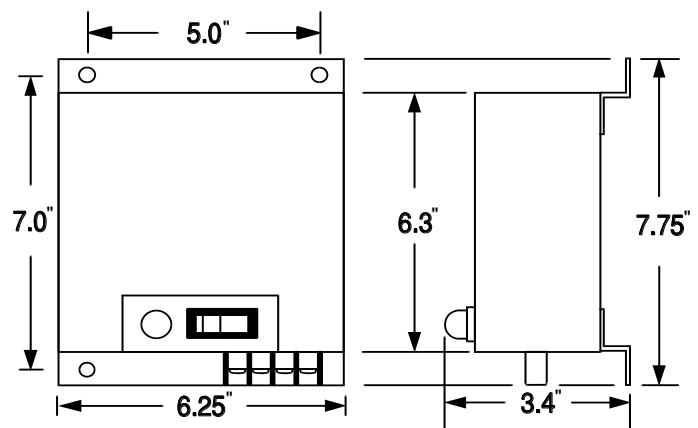

TIME MARK
CORPORATION

11/2011

© 2011 TIME MARK CORPORATION

TIME MARK is a division of  AEMT, Inc.

MODEL 410

Auto-Charged Capacitor Trip Device

READ ALL INSTRUCTIONS BEFORE INSTALLING, OPERATING OR SERVICING THIS DEVICE.
KEEP THIS DATA SHEET FOR FUTURE REFERENCE.

GENERAL SAFETY

POTENTIALLY HAZARDOUS VOLTAGES ARE PRESENT AT THE TERMINALS OF THE MODEL 410.
ALL ELECTRICAL POWER SHOULD BE REMOVED WHEN CONNECTING OR DISCONNECTING WIRING.
THIS DEVICE SHOULD BE INSTALLED AND SERVICED BY QUALIFIED PERSONNEL.

Installation Instructions

PRE-INSTALLATION CHECK

The energy storage capacitor used in the Model 410 is a special high grade, low leakage, industrial type electrolytic capacitor. One trait of any electrolytic capacitor is the tendency to change characteristics when left de-energized for extended periods.

Although these units have been completely tested at the factory, they may be stored for a considerable length of time. To insure proper performance, it is highly recommended that this unit be energized from the power source for a minimum two hours just before putting it into operation. This will insure that the unit will operate at maximum efficiency.

CHECK THE BATTERY. If the battery has run down, it is best to replace it, or to re-charge it **EXTERNALLY**, before installation.

INSTALLATION

Before putting the Model 410 into service, it should be examined carefully to make certain that the unit has not been damaged during shipment.

Verify that the supply voltage is of the proper value and frequency (*see Specifications table*).

Mount the Model 410 in the desired location.

Connect the operating power source and output tripping circuit (*refer to Typical Application example*).

CAUTION

The Model 410 uses a half-wave rectifier circuit to charge the energy storage capacitor from the source. **With this type of circuit, it is important that no load be placed across the energized capacitor (pins 1 & 3).**

Should this occur, no charge can be built up across the capacitor; the rectifier and current limiting resistor will then be subjected to prolonged, excessive current resulting in their **DESTRUCTION**.

Under normal operating conditions, the capacitor is protected from damage since its source is applied from either the battery and its associated circuitry, or from the circuit breaker, thus keeping all loads from the capacitor. There is ample time during a circuit breaker closing operation for the capacitor to charge since it requires only 3 cycles for the unit to reach 90% (*applies to 240VAC only*) of full charge.

During testing of the unit, with its associated circuit breaker, care should be exercised not to have the tripping circuit completed while applying AC voltage to a discharged unit.

OPERATION AND MAINTENANCE

The operation of the Model 410 is completely automatic, requiring only an occasional check to determine if the unit is functioning properly. A front panel neon light and rocker switch are supplied for this purpose. If the voltage across the capacitor is above the minimum required to operate the breaker, the light will glow when the test button is pressed. This indicates the readiness of the unit to trip the breaker, but it does not indicate the status of the external power source, or the internal battery circuit.

FIELD SERVICE AND ADJUSTMENT

The Model 410 has been completely checked and adjusted at the factory. It is advisable not to disturb these adjustments. If for any reason the unit fails to operate properly, it should be returned to the factory for repair, or re-calibration.

REPAIRS

The **Model 410 Auto-Charged Capacitor Trip Device** is not field repairable. Should this unit require repairs, call Time Mark Corporation at 800-862-2875 (*8 a.m. to 5 p.m. CST*) for instructions on returning it to the factory for service.

WARRANTY

This product is warranted to be free from defects in materials and workmanship for one year. Should this device fail to operate, we will repair it for one year from the date of manufacture. For complete warranty details, see the *Terms and Conditions of Sales* page in the front section of the Time Mark catalog or contact Time Mark at 1-800-862-2875.



11/2011

© 2011 TIME MARK CORPORATION

TIME MARK is a division of  AEMT, Inc.